

# Thermowell

## For sanitary applications

### Model TW22

WIKA data sheet TW 95.22



#### Applications

- Sanitary applications
- Food and beverage industry
- Bio and pharmaceutical industry, production of active ingredients

#### Special features

- Materials and surface finish quality in accordance with the standards of hygienic design
- Fully welded
- Can be combined with models TR21-A and TR22-A electrical resistance thermometers, measuring insert exchangeable
- Can be combined with mechanical thermometers, resistance thermometers and DiwiTherm®

#### Description

The model TW22 thermowell is used to adapt thermometers and measuring inserts to the process and protects the sensor against harsh process conditions. The thermowell is mounted to a weld-in nozzle equipped with a respective hygienic connection and is built in pipelines and tanks.

Through the rotatable threaded connection, the connection head or display can be loosened and adjusted to the desired position.

With a combination of a model TR21-A or TR22-A resistance thermometer, the connection head is removable along with the measuring insert. This enables the thermometer to be calibrated along with the complete measuring chain, i.e. without disconnecting the electrical connections. In addition, this avoids having to open the process, and thus the risk of contamination is minimised.



**Fig. left: Process connection welding ball**  
**Fig. right: Process connection VARIVENT®**

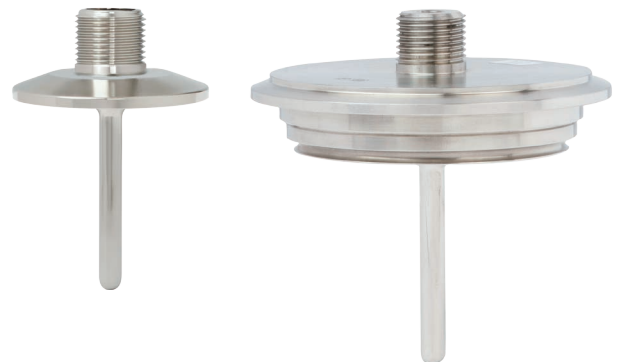

**Fig. left: Process connection Clamp with G 3/8"**  
**Fig. right: Process connection VARIVENT® with G 3/8"**

## Specifications

### Nominal width

see tables of dimensions

### Pressure ratings PN

see tables of dimensions

### Material

Wetted parts: stainless steel 1.4435 (316L, UNS S31603)

### Surface roughness of wetted parts

Standard:  $R_a < 0.76 \mu\text{m}$  (SF3 per ASME BPE)

Option:  $R_a < 0.38 \mu\text{m}$  (SF4 per ASME BPE)

$R_a < 0.38 \mu\text{m}$  electropolished (SF4 per ASME BPE)

### Connection to thermometer

In combination with:

- Resistance thermometer model TR21-A
  - G  $\frac{3}{8}$ " fixed
  
- Resistance thermometer model TR22-A
  - M24 x 1.5 male nut, rotatable
  - Option:  $\frac{1}{2}$  NPT, fixed
  
- Mechanical thermometers models 55 and 73 design 3 (union nut), DiwiTherm® model TR75
  - M24 x 1.5 male nut, rotatable
  - Option: Mechanical thermometers with design S (fixed), design 2 (rotatable threaded connection), design 4 (compression fitting), design 5 (union nut and loose threaded connection): G  $\frac{1}{2}$  female or  $\frac{1}{2}$  NPT female

### Thermowell diameter

- For resistance thermometers models TR21-A and TR22-A
  - $\varnothing 6$  mm for  $\varnothing 3$  mm sensors
  - $\varnothing 6$  mm tapered to  $\varnothing 4.5$  mm for  $\varnothing 3$  mm sensors (quick responding)
  - $\varnothing 4.5$  mm for  $\varnothing 3$  mm sensors (quick responding, only insertion length  $U_1 \leq 25$  mm)
  
- For mechanical thermometers models 55 and 73, DiwiTherm® model TR75
  - $\varnothing 8 \times 0.9$  mm for  $\varnothing 6$  mm sensors
  - $\varnothing 12 \times 1.5$  mm for  $\varnothing 8$  mm sensors

### Neck tube length M

85 mm

Other neck tube lengths on request

### Neck tube diameter

- Resistance thermometer model TR22-A
  - up to DN 20: 9 mm (except per DIN 11851 (milk thread fitting): 12 mm)
  - from DN 25: 12 mm
  
- Mechanical thermometers models 55 and 73, DiwiTherm® model TR75
  - same diameter as the thermowell diameter

### Insertion length $U_1$

25, 50, 75, 100, 150, 200 mm

Option: up to 400 mm according to customer specification

Insertion lengths for BioControl® flow-through housing: see table "Dimensions for NEUMO BioControl® process connection"

## Sealing combination (option)

The transition from the connection head to the thermowell is effected via an optional sealing combination (polyurethane) of flat gasket and wiper. This combination permanently prevents the penetration and depositing of humidity and impurities in this area (IP68). Additionally, the sealing combination simplifies the cleaning process significantly.

In combination with the patented BVS head and the cable gland in hygienic design, it delivers an easy-to-clean and hygienic measuring point, even in those areas not in contact with the product. The BVS head is designed in such a way that cleaning agents can run off easily and that no residues can accumulate on the case.

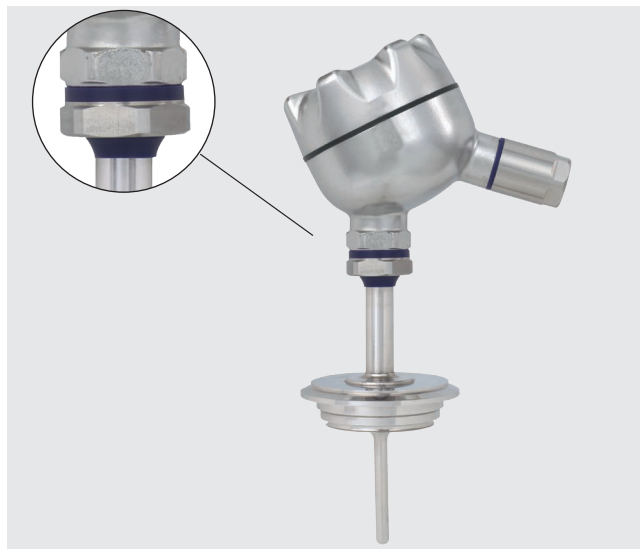



## Thermowell with tapered tip (option)

The thermowell can be designed with a tapered tip for an optimised response time. The massive shaft takes on the mechanical loads. Through the mass reduction at the sensor tip, the heat transfer to the sensor element is considerably improved. This shortens the response time of the measurement assembly. The minimum insertion length must thus be taken into account.

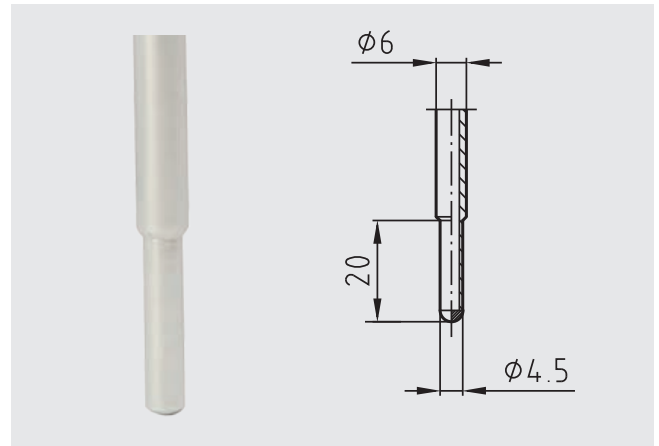
Thermowells with a tapered tip are favoured in media with poor heat transfer and are particularly recommended with gases.



## Approvals

Logo	Description	Country
	<b>3-A (Option) <sup>1)</sup></b> Sanitary Standard	USA
	<b>EHEDG (Option) <sup>1)</sup></b> Hygienic Equipment Design	European Community

## Patents, property rights

Case with easily cleanable twist crown, integrated into the case cap, is registered under no. GM 000984349

## Certificates (option)

- 2.2 test report
- 3.1 inspection certificate
- Manufacturer's declaration regarding Regulation (EC) 1935/2004
- Certificate of the surface roughness of wetted parts
- Hygiene certificates

Approval	3-A	EHEDG
<b>Clamp</b>	yes	yes <sup>3)</sup>
<b>VARIVENT®</b>	yes	yes
<b>BioConnect®</b>	yes	no
<b>DIN 11851</b>	yes <sup>2)</sup>	yes <sup>2)</sup>
<b>DIN 11864-1</b>	yes	yes
<b>DIN 11864-2</b>	yes	yes
<b>DIN 11864-3</b>	yes	yes
<b>Welding ball</b>	yes	no
<b>Compression fitting</b>	no	no
<b>SMS</b>	no	no

1) Confirmation of 3-A or EHEDG conformity only valid with separately selectable 2.2 test report

2) In combination with  
 - ASEPTO-STAR k-flex upgrade gaskets from Kieselmann GmbH, Germany or  
 - SKS gasket set DIN 11851 EHEDG from Siersema Componenten Service (S.K.S.) B.V., Netherlands

3) In combination with  
 - Kalrez/Stainless steel gasket from Dupont de Nemours, Switzerland or  
 - T-ring seals from CombiFit International B.V., Netherlands

Approvals and certificates, see website

## Combination possibilities

- Resistance thermometers models TR21-A or TR22-A
- Mechanical thermometers models 55 or 73
- DiwiTherm® model TR75

## Combination examples

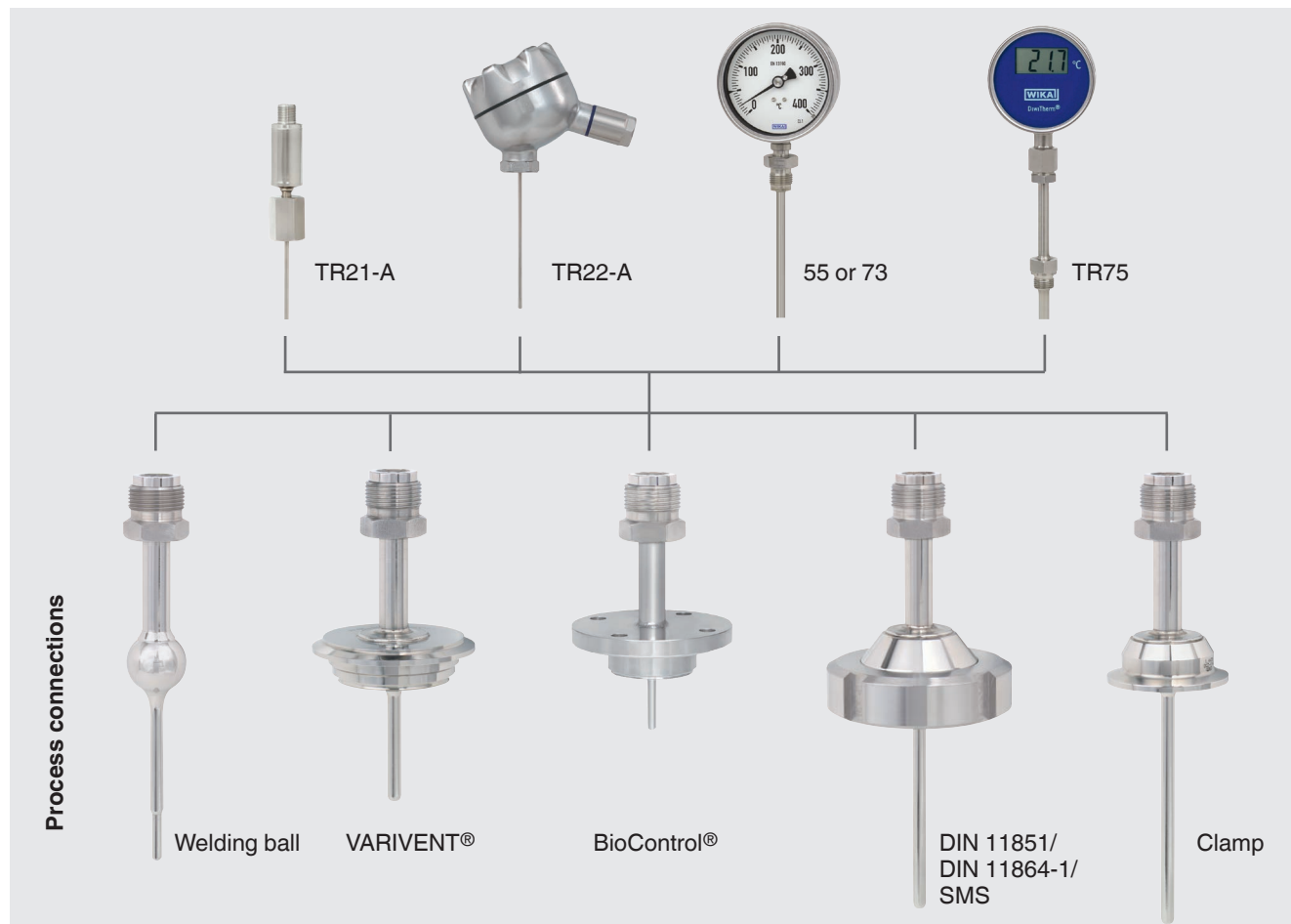

VARIVENT® and VARINLINE® are registered trademarks of the company GEA Tuchenhagen.  
BioControl® is a registered trademark of the company NEUMO.

## Calculating the insertion length of the thermometer

### Mechanical thermometers models 55 and 73

- Design 2  
 $L_1 = U_1 (TW22) + M - 25 \text{ mm}$
- Design 3  
 $L_1 = U_1 (TW22) + M - 5 \text{ mm}$

### DiwiTherm® model TR75

$$A(I_1) \text{ or } A(U_2) = U_1 (TW22) + M (TW22) - 15 \text{ mm}$$

### Resistance thermometer model TR21-A

$$L_1 = U_1^{1)} + M^{2)}$$

### Resistance thermometer model TR22-A

$$\text{Sensor length } l_5 = U_1^{1)} + M^{3)} + 10 \text{ mm}$$

- 1) Through their small design, face-sensitive measuring resistors serve to reduce the heat dissipation with short insertion lengths. Available for the temperature range up to 150 °C (302 °F). For thermowell insertion lengths of less than 50 mm, face-sensitive measuring resistors are recommended. For thermowell insertion lengths of less than 11 mm, face-sensitive measuring resistors are generally used.
- 2) Neck tube length M see data sheet TE 60.26 (TR21-A)
- 3) Neck tube length M see data sheet TE 60.22 (TR22-A)

### Legend:

- M Neck tube length
- $U_1$  Insertion length thermowell
- $L_1$  Insertion length mechanical thermometers
- $A(I_1) \text{ or } A(U_2)$  Insertion length DiwiTherm®
- $L_1$  Insertion length TR21-A
- $l_5$  Insertion length TR22-A

# Fundamental thermowell design

For mechanical thermometers models 55 and 73

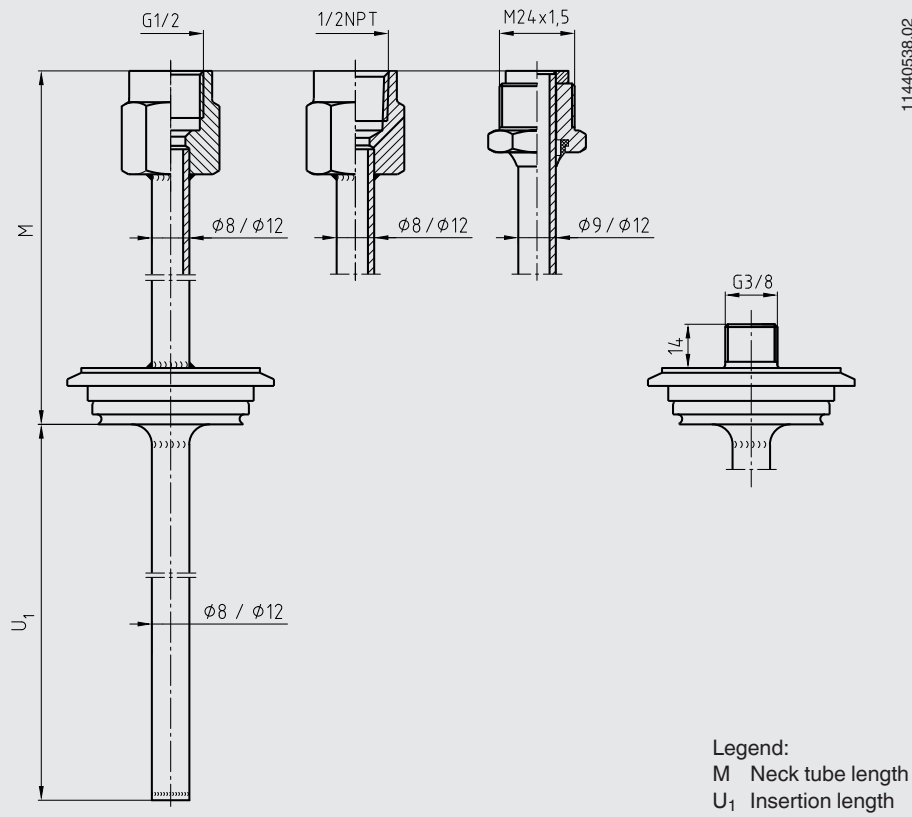

For resistance thermometers models TR21-A and TR22-A

M24 x 1.5 for model TR22-A

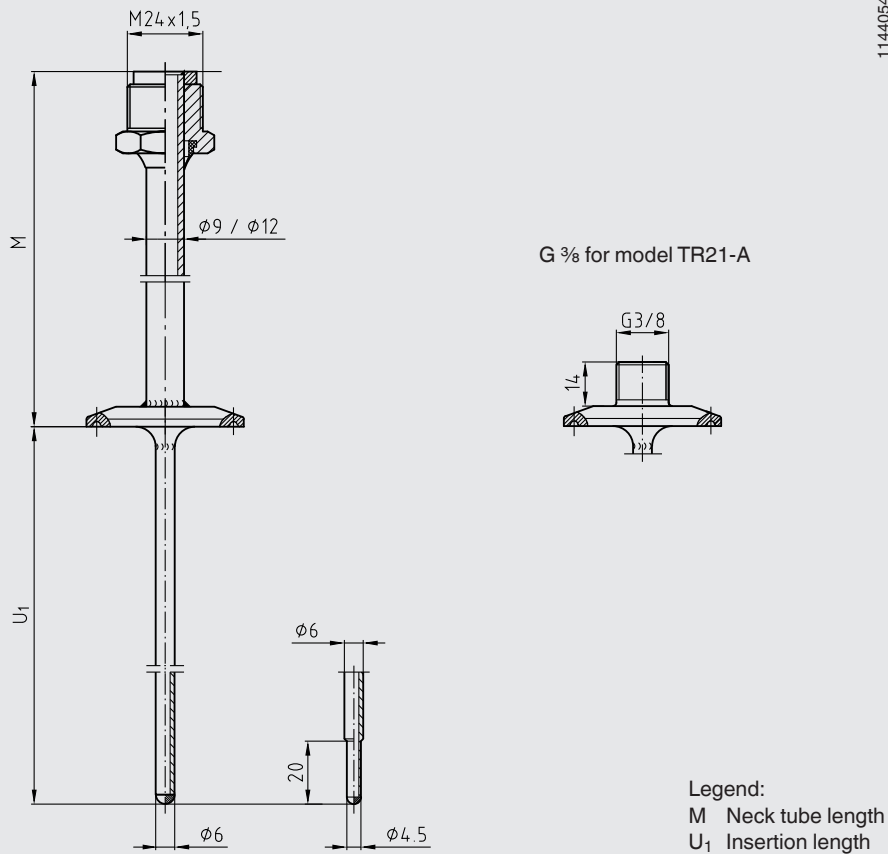

## Dimensions of the process connections in mm

### Clamp process connection

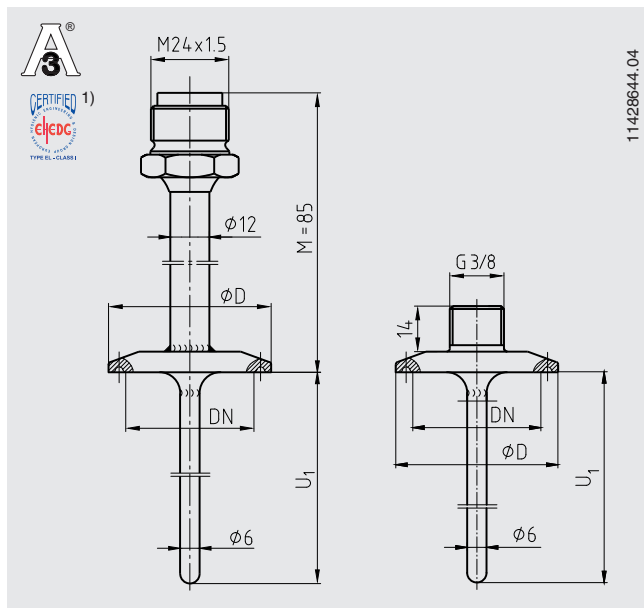

### VARIVENT® process connection

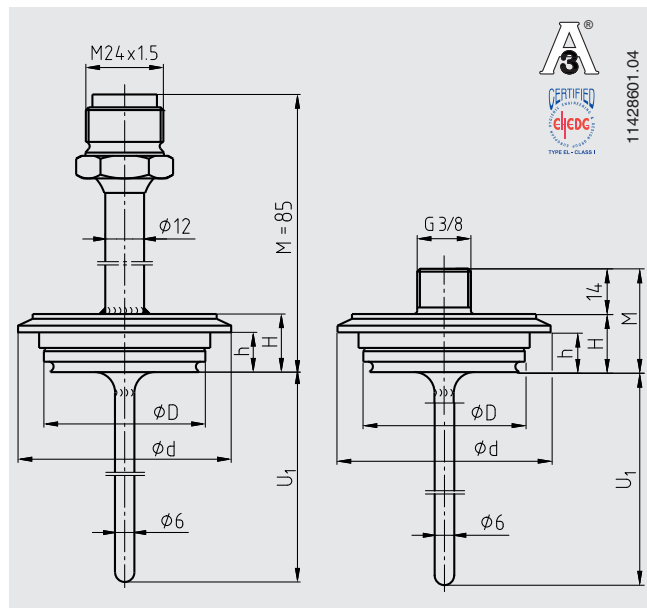

$U_1$  = variable insertion length

$U_1$  = variable insertion length

- 1) In combination with  
 - Kalrez/Stainless steel gasket from Dupont de Nemours, Switzerland or  
 - T-ring seals from Combifit International B. V., Netherlands

### Dimensions for clamp process connection

Process connection	Nominal width in mm/inch	PN in bar	Dimensions in mm		Weight in kg
			$\varnothing D$		
DIN 32676 for pipes per DIN 11866 row A	DN 10 ... 20	25	34.0		0.2
	DN 25 ... 40	25	50.5		0.3
	DN 50	16	64.0		0.4
DIN 32676 for pipes per DIN 11866 row B	13.5 ... 17.2	25	25.0		0.2
	21.3 ... 33.7	25	50.5		0.3
	42.4 ... 48.3	16	64.0		0.3
DIN 32676 for pipes per DIN 11866 row C	1/2" ... 3/4"	25	25.0		0.2
	1" ... 1 1/2"	25	50.5		0.3
	2"	16	64.0		0.4
Tri-clamp	1/2" ... 3/4"	13.8	25.0		0.2
	1" ... 1 1/2"	13.8	50.5		0.3
	2"	13.8	64.0		0.4
	2 1/2"	13.8	77.5		0.4
	3"	13.8	91.0		0.5
ISO 2852	DN 12 ... 21.3	16	34.0		0.2
	DN 25 ... 38	16	50.5		0.3
	DN 40 ... 51	16	64.0		0.4

### Dimensions for VARIVENT® process connection

Process connection	Nominal width in mm	PN in bar	Dimensions in mm				Weight in kg
			$\varnothing D$	$\varnothing d$	H	h	
Form B	DN 10, DN 15	25	31	52.7	20	13.65	0.3
Form F	DN 25, DN 32	25	50	66.0	18	12.30	0.4
Form N	DN 40, DN 50	25	68	84.0	18	12.30	0.6

## Union nut process connection DIN 11851 with conical coupling (milk thread fitting)

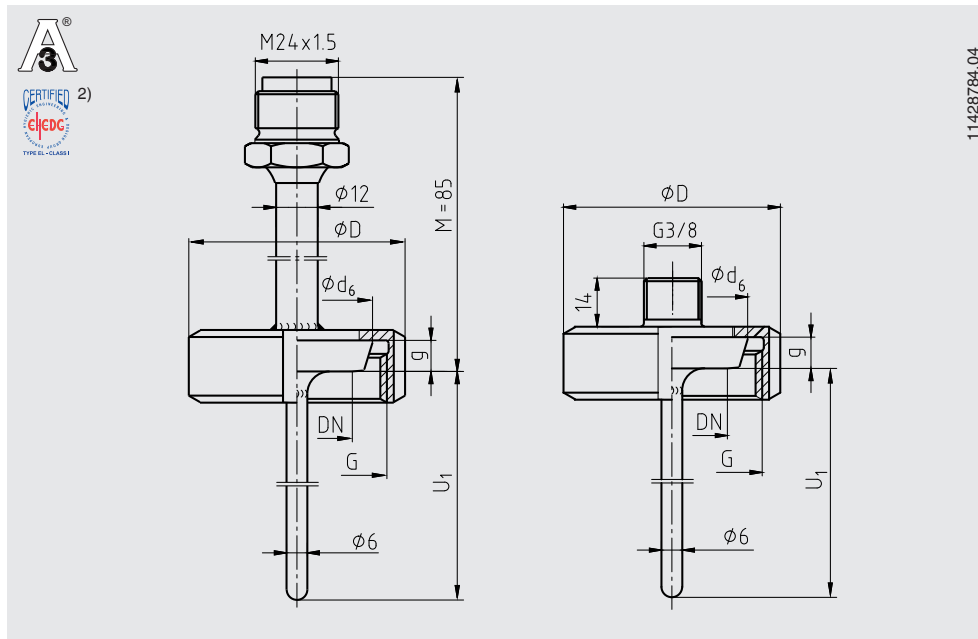

11428784.04

Nominal width in mm	PN in bar	Dimensions in mm				Weight in kg
		$\phi d_6$	G	$\phi D$	g	
DN 20	40	36.5	RD 44 x 1/6	54	8	0.40
DN 25	40	44.0	RD 52 x 1/6	63	10	0.50
DN 32	40	50.0	RD 58 x 1/6	70	10	0.60
DN 40	40	56.0	RD 65 x 1/6	78	10	0.80
DN 50	25	68.5	RD 78 x 1/6	92	11	0.90

$U_1$  = variable insertion length

- 2) In combination with
- ASEPTO-STAR k-flex upgrade gaskets from Kieselmann GmbH, Germany or
  - SKS gasket set DIN 11851 EHEDG from Siersema Komponenten

**Aseptic threaded pipe process connection, DIN 11864-1 with liner form A, for pipes in accordance with DIN 11866 row A, B und C**

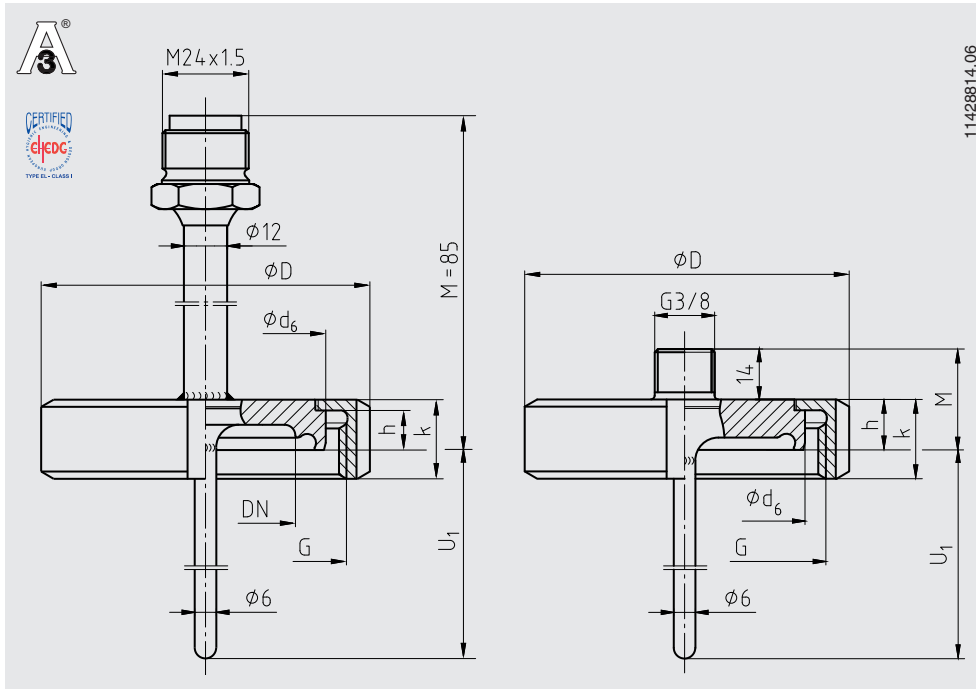

U<sub>1</sub> = variable insertion length

Nominal width of pipe DN / OD	Nominal pressure in bar PN	Outer diameter of pipe	Pipe schedule s	Inner diameter of pipe	Process connection				Aseptic O-ring	Weight in kg
					Ø D	G	h	k		
<b>DIN 11866 row A or metric</b>										
10	40	13	1.5	10	38	RD 28 x 1/8	9	18	12 x 3.5	0.2
15	40	19	1.5	16	44	RD 34 x 1/8	9	18	18 x 3.5	0.2
20	40	23	1.5	20	54	RD 44 x 1/6	10	20	22 x 3.5	0.25
25	40	29	1.5	26	63	RD 52 x 1/6	12	21	28 x 3.5	0.4
32	40	35	1.5	32	70	RD 58 x 1/6	13	21	34 x 5	0.45
40	40	41	1.5	38	78	RD 65 x 1/6	13	21	40 x 5	0.55
50	25	53	1.5	50	92	RD 78 x 1/6	14	22	52 x 5	0.7
<b>DIN 11866 row B or ISO</b>										
8 (13.5)	40	13.5	1.6	10.3	38	RD 28 x 1/8	9	18	12 x 3.5	0.2
10 (17.2)	40	17.2	1.6	14	44	RD 34 x 1/8	9	18	16 x 3.5	0.2
15 (21.3)	40	21.3	1.6	18.1	54	RD 44 x 1/6	10	20	20 x 3.5	0.3
20 (26.9)	40	26.9	1.6	23.7	63	RD 52 x 1/6	12	21	26 x 3.5	0.4
25 (33.7)	40	33.7	2	29.7	70	RD 58 x 1/6	13	21	32 x 5	0.5
32 (42.4)	25	42.4	2	38.4	78	RD 65 x 1/6	13	21	40.5 x 5	0.6
40 (48.3)	25	48.3	2	44.3	92	RD 78 x 1/6	14	22	46.6 x 5	0.7
<b>DIN 11866 row C or ASME BPE</b>										
1/2"	40	12.7	1.65	9.4	38	RD 28 x 1/8	9	18	12 x 3.5	0.2
3/4"	40	19.05	1.65	15.75	44	RD 34 x 1/8	9	18	18 x 3.5	0.2
1"	40	25.4	1.65	22.1	63	RD 52 x 1/6	12	21	24 x 3.5	0.4
1 1/2"	40	38.1	1.65	34.8	78	RD 65 x 1/6	13	21	37 x 5	0.6
2"	25	50.8	1.65	47.5	92	RD 78 x 1/6	14	22	50 x 5	0.7



# Aseptic flange process connection DIN 11864-2, form A for pipes in accordance with DIN 11866 row A

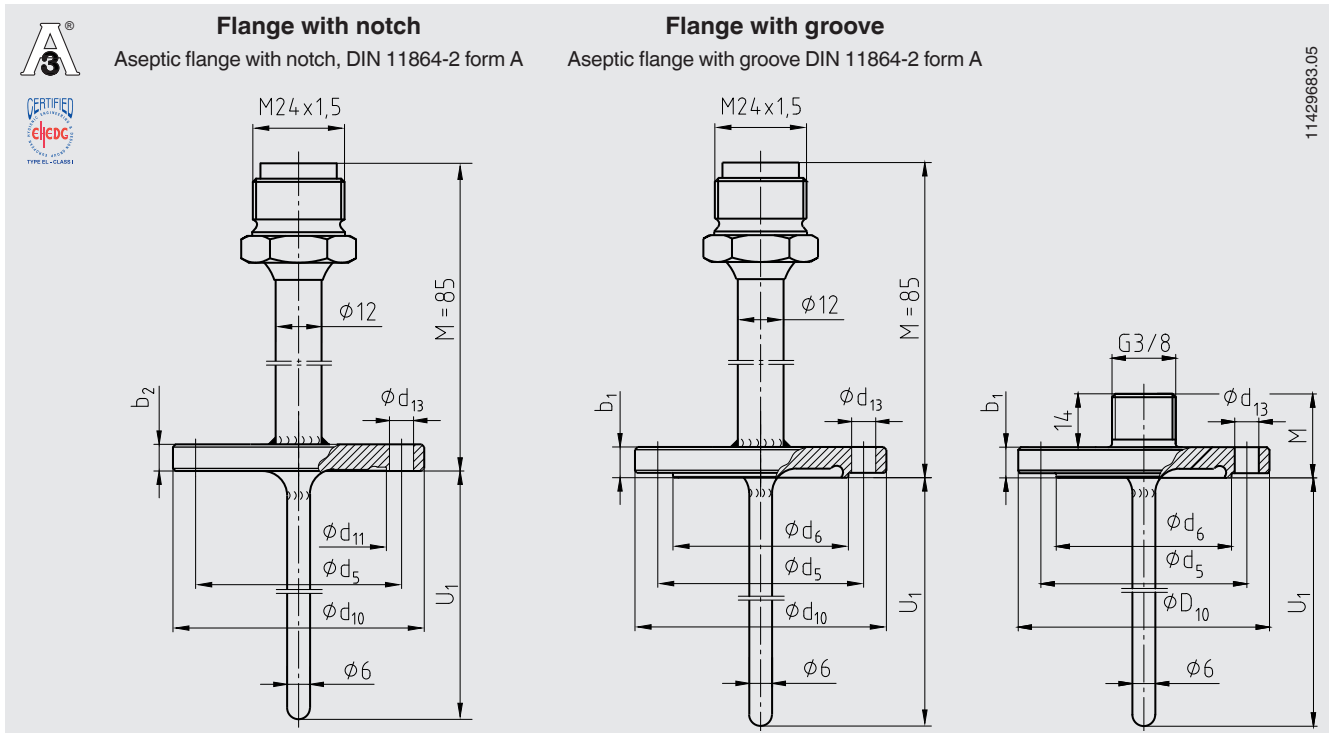

11429683.05

Process connection	Nominal width in mm	PN in bar	Dimensions in mm								Aseptic O-ring	Weight in kg
			b <sub>1</sub>	b <sub>2</sub>	Ø d <sub>5</sub>	Ø d <sub>6</sub>	Ø d <sub>10</sub>	Ø d <sub>11</sub>	Ø d <sub>13</sub>			
Flange with notch	DN 10	25	-	10	37	-	54	22.4	4 x Ø 9	12 x 3.5	0.2	
	DN 15	25	-	10	42	-	59	28.4	4 x Ø 9	18 x 3.5	0.25	
	DN 20	25	-	10	47	-	64	32.4	4 x Ø 9	22 x 3.5	0.3	
	DN 25	25	-	10	53	-	70	38.4	4 x Ø 9	28 x 3.5	0.4	
	DN 32	25	-	10	59	-	76	47.7	4 x Ø 9	34 x 5	0.4	
	DN 40	25	-	10	65	-	82	53.7	4 x Ø 9	40 x 5	0.5	
	DN 50	16	-	10	77	-	94	65.7	4 x Ø 9	52 x 5	0.6	
Flange with groove	DN 10	25	11.5	-	37	22.3	54	-	4 x Ø 9	12 x 3.5	0.25	
	DN 15	25	11.5	-	42	28.3	59	-	4 x Ø 9	18 x 3.5	0.3	
	DN 20	25	11.5	-	47	32.3	64	-	4 x Ø 9	22 x 3.5	0.3	
	DN 25	25	11.5	-	53	38.3	70	-	4 x Ø 9	28 x 3.5	0.4	
	DN 32	25	11.5	-	59	47.6	76	-	4 x Ø 9	34 x 5	0.45	
	DN 40	25	11.5	-	65	56.6	82	-	4 x Ø 9	40 x 5	0.6	
	DN 50	16	11.5	-	77	65.6	94	-	4 x Ø 9	52 x 5	0.7	

Connections for pipes in accordance with DIN 11866 row B (ISO pipes) and row C (ASME pipes) available on request.

**Aseptic clamp process connection, DIN 11864-3, form A for pipes in accordance with DIN 11866 row A**

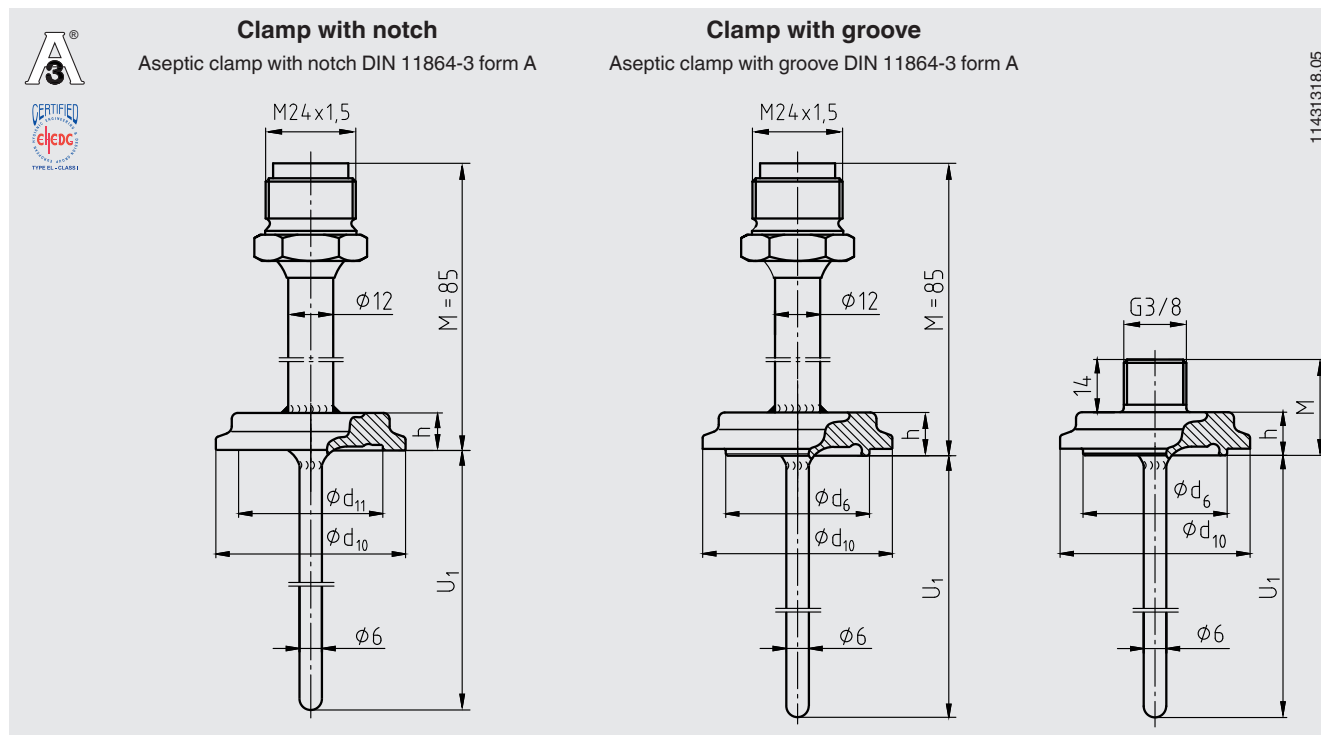

11431318.05

Process connection	Nominal width in mm	PN in bar	Dimensions in mm					Aseptic O-ring	Weight in kg
			Ø d <sub>6</sub>	Ø d <sub>10</sub>	Ø d <sub>11</sub>	h			
<b>Clamp with notch</b>	DN 10	40	-	34	22.4	10	12 x 3.5	0.2	
	DN 15	40	-	34	28.4	10	18 x 3.5	0.2	
	DN 20	40	-	50.5	32.4	10	22 x 3.5	0.3	
	DN 25	40	-	50.5	38.4	10	28 x 3.5	0.3	
	DN 32	40	-	50.5	47.7	10	34 x 5	0.3	
	DN 40	40	-	64	53.7	10	40 x 5	0.4	
	DN 50	25	-	77.5	65.7	10	52 x 5	0.5	
<b>Clamp with groove</b>	DN 10	40	22.3	34	-	11.5	12 x 3.5	0.2	
	DN 15	40	28.3	34	-	11.5	18 x 3.5	0.2	
	DN 20	40	32.3	50.5	-	11.5	22 x 3.5	0.3	
	DN 25	40	38.3	50.5	-	11.5	28 x 3.5	0.3	
	DN 32	40	47.6	50.5	-	11.5	34 x 5	0.3	
	DN 40	40	53.6	64	-	11.5	40 x 5	0.4	
	DN 50	25	65.6	77.5	-	11.5	52 x 5	0.5	

Connections for pipes in accordance with DIN 11866 row B (ISO pipes) and row C (ASME pipes) available on request.

## NEUMO BioControl® process connection

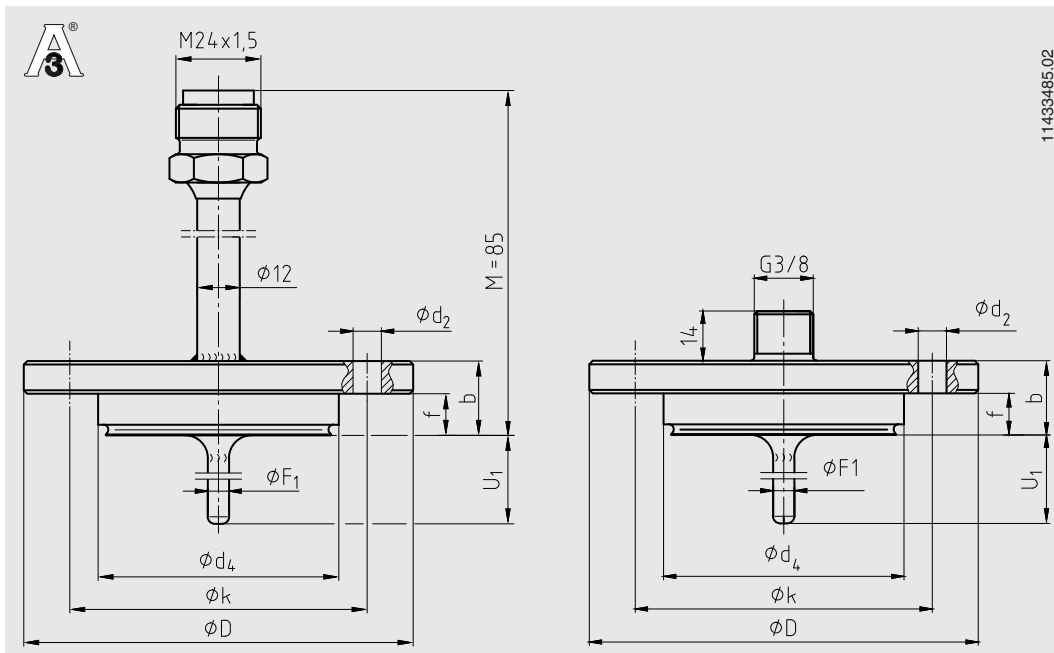

$U_1$  = variable insertion length

For fitting into a flow-through housing, the insertion length  $U_1$  and the thermowell diameter must be matched. For angular housings, the insertion length  $U_1$  must be specified by the customer.

The cases are not part of the scope of delivery of the resistance thermometers and can be ordered as a separate item. For a detailed description of the BioControl® cases, see data sheet AC 09.14.

Case size	Nominal width of pipe	PN in bar	Dimensions in mm							Weight in kg
			$U_1$	$\varnothing d_4$	$\varnothing D$	f	b	$\varnothing k$	$\varnothing d_2$	
Size 25	DN 8	16	5	30.5	64	11	20	50	4 x $\varnothing 7$	0.4
	DN 10	16	6	30.5	64	11	20	50	4 x $\varnothing 7$	0.4
	DN 15	16	9	30.5	64	11	20	50	4 x $\varnothing 7$	0.4
	DN 20	16	11	30.5	64	11	20	50	4 x $\varnothing 7$	0.4
Size 50	DN 25	16	15	50.0	90	17	27	70	4 x $\varnothing 9$	0.8
	DN 40	16	20	50.0	90	17	27	70	4 x $\varnothing 9$	0.8
	DN 50	16	25	50.0	90	17	27	70	4 x $\varnothing 9$	0.8
	DN 65	16	35	50.0	90	17	27	70	4 x $\varnothing 9$	0.8
	DN 80	16	45	50.0	90	17	27	70	4 x $\varnothing 9$	0.8
	DN 100	16	55	50.0	90	17	27	70	4 x $\varnothing 9$	0.8
Size 65	DN 40	16	20	68.0	120	17	27	95	4 x $\varnothing 11$	1.4
	DN 50	16	25	68.0	120	17	27	95	4 x $\varnothing 11$	1.4
	DN 65	16	35	68.0	120	17	27	95	4 x $\varnothing 11$	1.4
	DN 80	16	45	68.0	120	17	27	95	4 x $\varnothing 11$	1.4
	DN 100	16	55	68.0	120	17	27	95	4 x $\varnothing 11$	1.4

## Compression fitting process connection

### Ball-type compression fitting

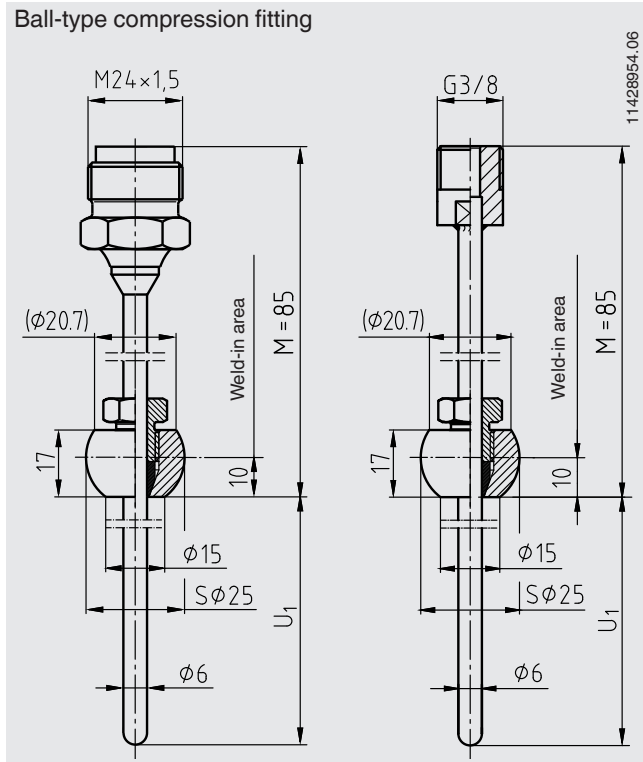

### Collar-type compression fitting

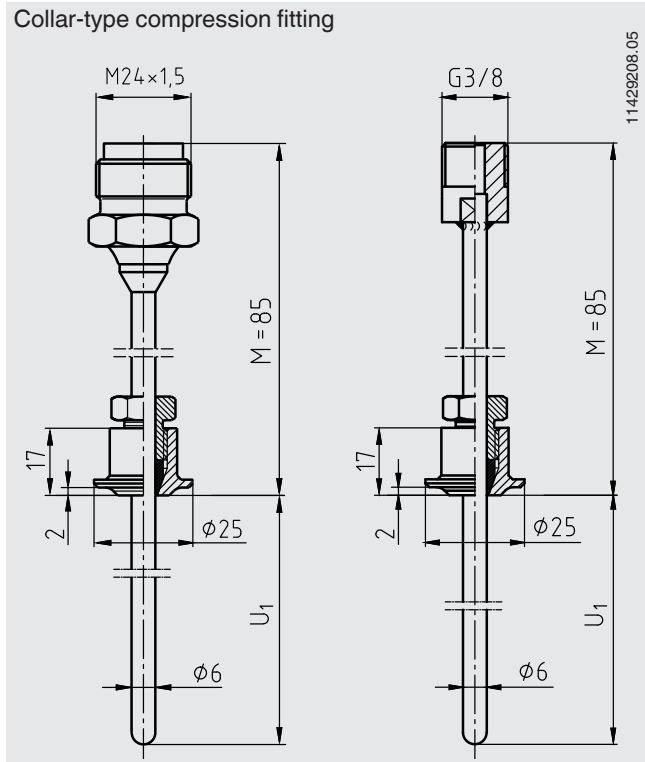

### Process connection, smooth, $\phi 6$ mm, basic shape for compression fitting

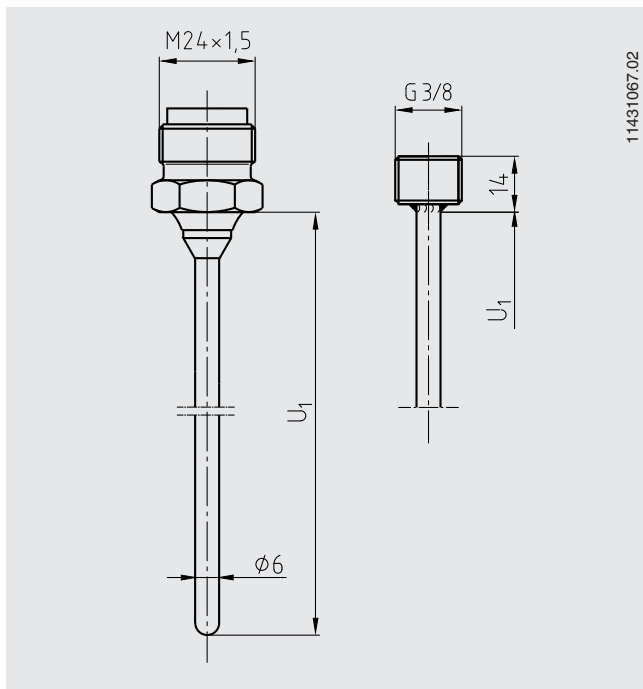

### Welding ball process connection

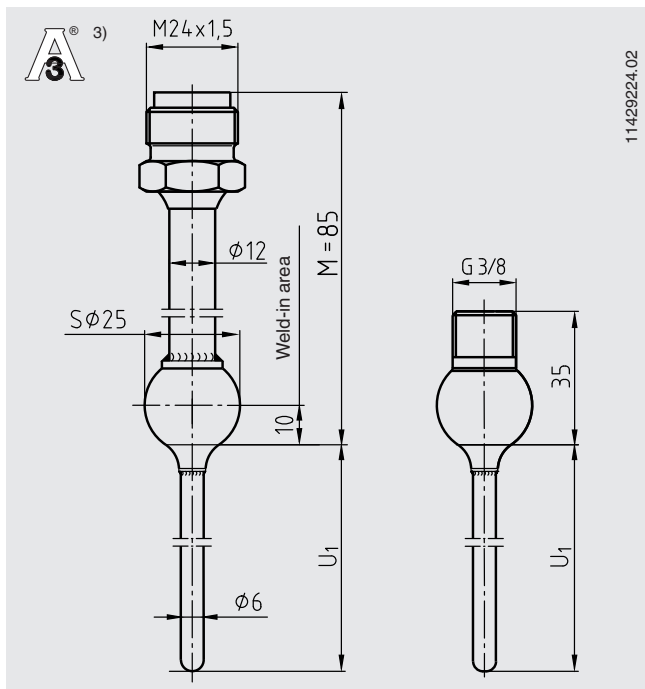

3) In order to meet the 3-A standard, the weld seam must be finished with a minimum radius of 3.2 mm on the product side. In this way, no weld defects, such as recesses or gaps, remain.

## Union nut process connection SMS

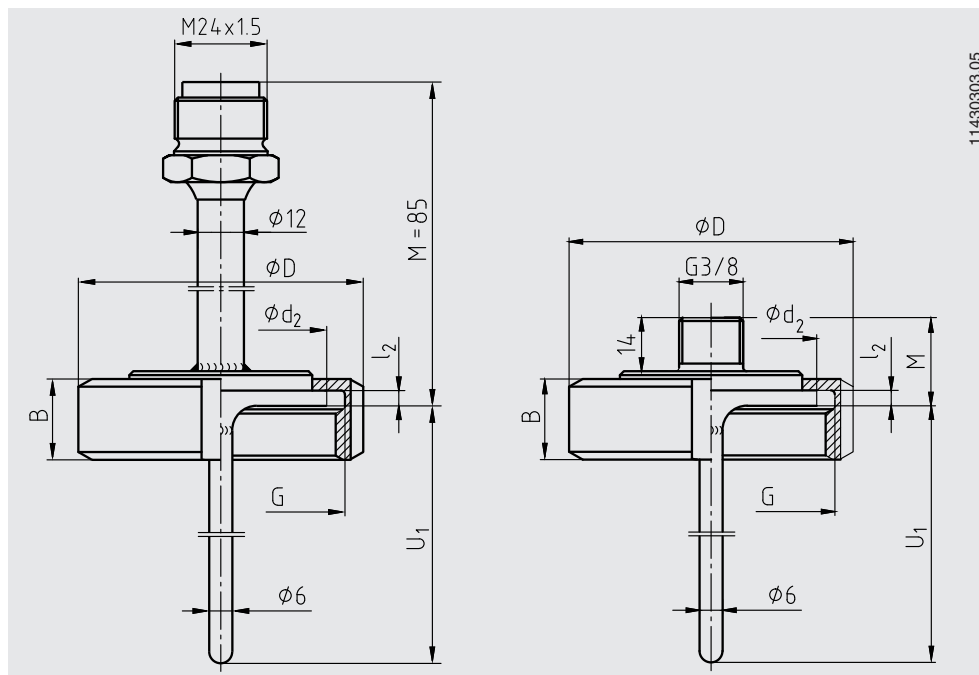

Nominal width in inch	PN in bar	Dimensions in mm					Weight in kg
		Ø D	Ø d <sub>2</sub>	B	l <sub>2</sub>	G	
1"	40	51	35.5	25	3.5	RD 40 x 1/6	0.4
1½"	40	74	55.0	25	4.0	RD 60 x 1/6	0.8
2"	40	84	65.0	26	4.0	RD 70 x 1/6	1.0

### Ordering information

Model / Type of process connection / Nominal width / Thermowell material / Surface roughness of the wetted parts / Connection to thermometer (N) / Insertion length U<sub>1</sub> / Thermowell diameter / Neck tube length M / Neck tube diameter / Assembly with resistance thermometer / Thermometer / Certificates / Options

© 03/2009 WIKA Alexander Wiegand SE & Co. KG, all rights reserved.  
The specifications given in this document represent the state of engineering at the time of publishing.  
We reserve the right to make modifications to the specifications and materials.

